



Hydro Solo-E

Complete pressure boosting systems
50/60 Hz



Contents

Product data

Performance range	3
Hydro Solo-E	4
Operating conditions	4
Inlet pressure	4
Type key	4
Product range	5
Construction	5
Installation	5
Mechanical installation	6
Diaphragm tank	6
Curve conditions	6
Electrical connection	6

Control of CRE pumps

Control options of CRE pumps	7
Central management system	7
Remote control	7
Control panel	7
Overview of functions	8

Electrical installation

Additional protection	9
Wiring diagram, single-phase	9
Wiring diagram, three-phase 1.5 - 7.5 kW	9

Technical data

Hydro Solo-E, CRE 1-xx	10
Hydro Solo-E, CRE 3-xx	11
Hydro Solo-E, CRE 5-xx	12
Hydro solo-E, CRE 10-xx	13
Hydro Solo-E, CRE 15-xx	14
Hydro Solo-E, CRE 20-xx	15
Hydro Solo-E, CRE 32-xx	16
Hydro Solo-E, CRE 45-xx	17

Accessories

R100	18
Dry-running protection	18

Further product documentation

WinCAPS	19
WebCAPS	20

Performance range

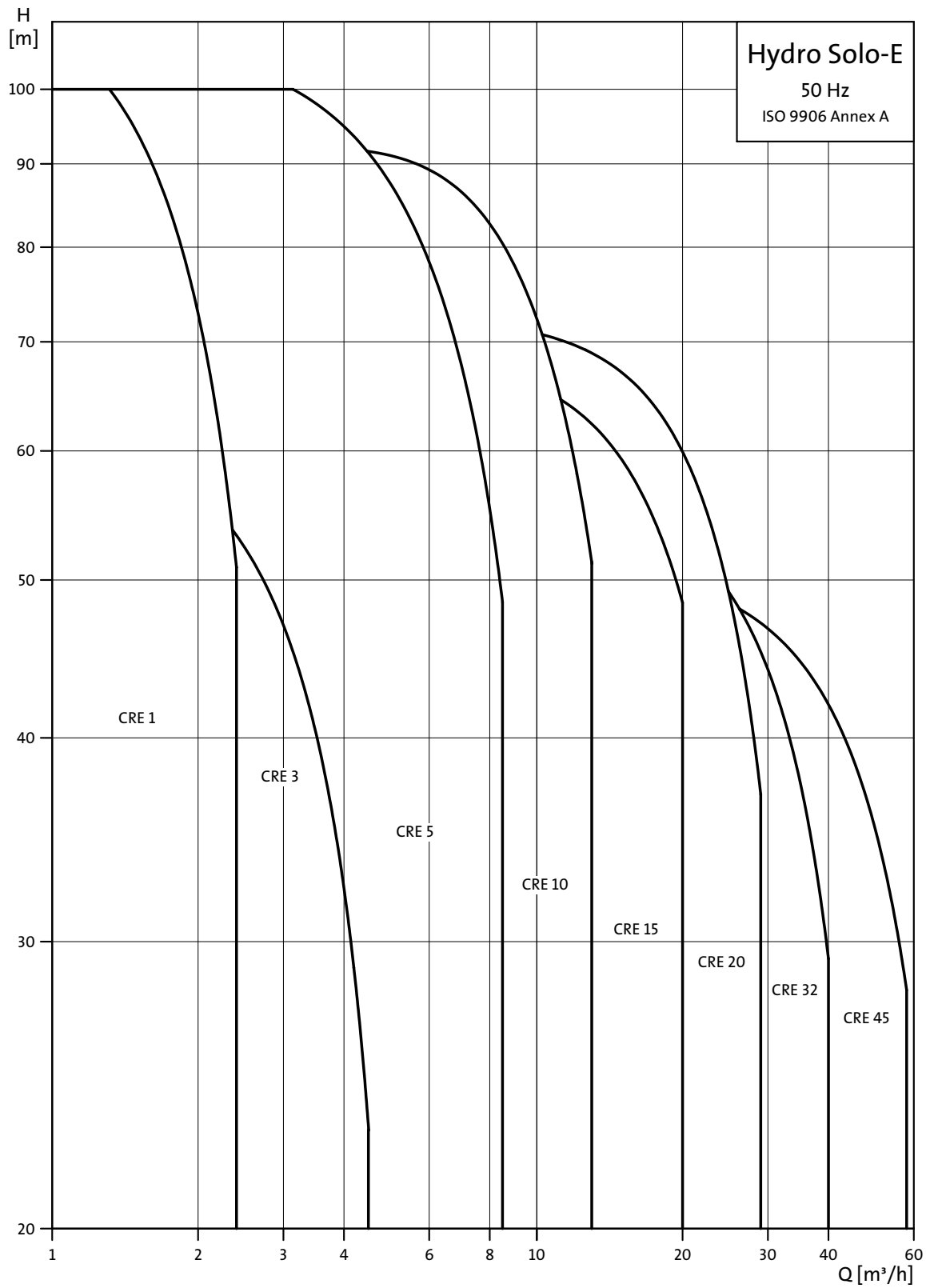

TM02 75773803

Hydro Solo-E

Grundfos Hydro Solo-E booster set with one pump is a combined unit consisting of one E-pump (CRE) fitted with isolating valve, non-return valve, discharge pipe, pressure transmitter, pressure gauge and diaphragm tank.

Upon delivery the booster set is ready for operation.

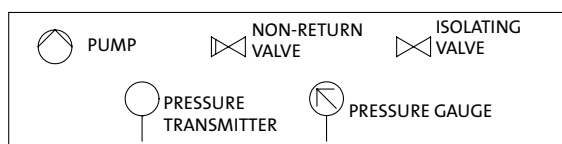
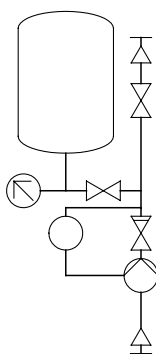

Fig. 1 Principal sketch of Hydro Solo-E

Operating conditions

- Liquid temperature:** 0°C to +70°C
- Ambient temperature:** 0°C to +40°C
- System pressure:** The maximum system pressure is 10 bar.

The total of inlet pressure and head must not exceed the maximum system pressure.

Inlet pressure

Minimum inlet pressure:

The minimum inlet pressure H in metres head required to avoid cavitation in the pump is calculated as follows:

$$H = p_b \times 10.2 - \text{NPSH} - H_f - H_v - H_s$$

p_b = Barometric pressure in bar.
Barometric pressure can be set to 1, if required.

NPSH = Net Positive Suction Head in metres head.
NPSH can be read from the NPSH curve at the maximum capacity at which the pump will run.

H_f = Friction loss in suction pipe in metres head.

H_v = Vapour pressure in metres head.

H_s = Safety margin of min. 0.5 metres head.

Maximum inlet pressure.

CRE 1	
1-7, 1-15, 1-19	10 [bar]
CRE 3	
3-7, 3-10	10 [bar]
CRE 5	
5-4, 5-8, 5-10, 5-16	10 [bar]
CRE 10	
10-3, 10-4, 10-6	8 [bar]
10-9	10 [bar]
CRE 15	
15-2, 15-3	8 [bar]
15-5	10 [bar]
CRE 20	
20-3	8 [bar]
20-5	10 [bar]
CRE 32	
32-3	4 [bar]
CRE 45	
45-2	4 [bar]

Example of operating and inlet pressures

The values for operating and inlet pressures must not be considered individually but must always be compared, see the following example:

Example:

The following pump type has been selected:
CRE 10-4 A-A-A

- Max. operating pressure: **10 bar**
- Max. inlet pressure: **8 bar**
- Desired pressure boosting: **2 bar**

This pump is allowed to start at an inlet pressure of 8 bar as the discharge pressure is only 2 bar which results in an operating pressure of $8.0 + 2 = 10$ bar.

Type key

Single-phase:

Example	Hydro	Solo-E	CRE 5-8	1 x 200-240 V
Type range				
Subgroup				
Pump type				
Supply voltage				

Three-phase:

Example	Hydro	Solo-E	CRE 10-4	1 x 200-240 V
Type range				
Subgroup				
Pump type				
Supply voltage				

Product range

Pump type	Motor [kW]	Pressure transmitter [bar]	Product numbers	
			1 x 220 - 240 V	3 x 380 - 480 V
CRE 1-7	0.37	0-10	96467828	-
CRE 1-15	0.75	0-10	96467860	-
CRE 1-19	1.1	0-10	96467861	-
CRE 3-7	0.55	0-10	96467864	-
CRE 3-10	0.75	0-10	96457865	-
CRE 3-10	1.1	0-10	-	96468197
CRE 5-4	0.55	0-10	96467867	-
CRE 5-8	1.1	0-10	96467868	96479543
CRE 5-10	1.5	0-10	-	96467871
CRE 5-16	2.2	0-10	-	96467872
CRE 10-3	1.1	0-10	96513873	-
CRE 10-4	1.5	0-10	-	96513874
CRE 10-6	2.2	0-10	-	96513875
CRE 10-9	3.0	0-10	-	96513876
CRE 15-2	2.2	0-10	-	96513877
CRE 15-3	3.0	0-10	-	96513878
CRE 15-5	4.0	0-10	-	96513879
CRE 20-3	4.0	0-10	-	96513880
CRE 20-5	5.5	0-10	-	96513881
CRE 32-3	5.5	0-10	-	96468199
CRE 45-2	5.5	0-10	-	96468210

Construction

Pos.	Designation	Qty.
1	CRE pump	1
2	Diaphragm tank	1
3	Pressure gauge	1
4	Isolating valve for diaphragm tank and pressure gauge	1
5	Isolating valve	1
6	Discharge pipe (stainless steel)	1
7	Pressure transmitter	1
8	Non-return valve	1
9	On/off-switch	1
10	Nameplate	1

On the discharge side of the pump are fitted a non-return valve, a stainless steel discharge pipe (EN/DIN 1.4401 or EN/DIN 1.4571) and an isolating valve.

On the discharge pipe are fitted a pressure transmitter and an isolating valve for the pressure gauge and the diaphragm tank.

The pump is fitted with an on/off-switch for the supply voltage.

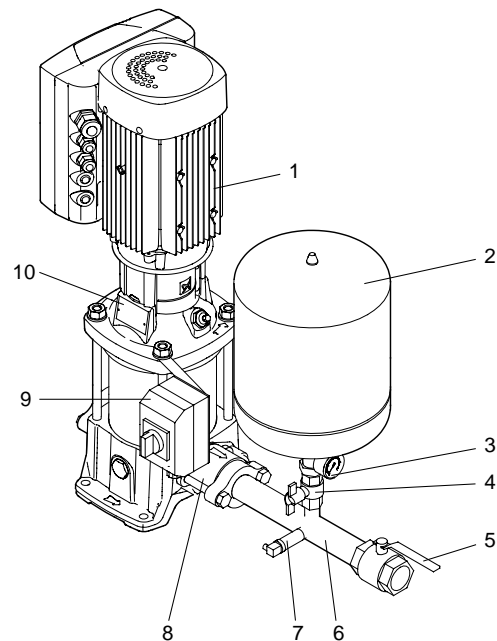

Fig. 2 Construction of Hydro Solo-E

Installation

A Hydro Solo-E booster set must be installed in a well ventilated room to ensure sufficient cooling for the pump. Hydro Solo-E is not suitable for outdoor installation.

The booster set should be placed with sufficient clearance around it.

Enclosure class: IP 55

Insulation class: F.

TM027562-3803

Mechanical installation

The pipes connected to the booster set must be of adequate size. To avoid resonance, expansion joints should be fitted both in the discharge and suction pipes.

The pipes are to be connected to the discharge pipe and the pump suction port.

The booster set should be tightened up prior to start-up.

It is always advisable to fit pipe hangers both on the suction and discharge side.

The system should be positioned on an even and solid surface, e.g. a concrete floor or foundation. If the booster set is not fitted with vibration dampers, it must be bolted to the floor or foundation.

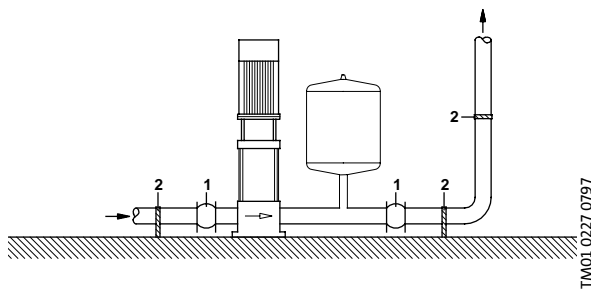

Fig. 3 Mechanical installation

1. Expansion joints
2. Pipe hangers

Expansion joints and pipe hangers shown are not included in a standard booster set.

Diaphragm tank

The diaphragm tank is pre-charged to correct pressure. If the setpoint is altered, a new pre-charge pressure should be calculated to obtain optimal duty:

Calculation of pre-charge pressure:

- Pre-charge pressure = 0.7 x setpoint

The diaphragm tank's pre-charge pressure must be measured in a pressureless system.

It is recommended to refill the tank with nitrogen.

Curve conditions

The following curves are subject to the following guidelines:

- Performance measurement is made at a water temperature of +20°C.
- Test liquid: Pure water.
- The curves describe the pump mean values.
- **The curves should not be used as guarantee curves.**
- Curve tolerance: ISO 9906, Annex A.
- The conversion between head H(m) and pressure p (kPa) has been made for water with a density of $\rho = 1000 \text{ kg/m}^3$.
- The curves apply to a kinematic viscosity of $1 \text{ mm}^2/\text{s}$ (1 cSt).

Electrical connection

The electrical connection and protection should be carried out in accordance with local regulations.

- The pump must be connected to an external mains switch.
- The E-pump must always be correctly earthed. **Note:** The 4.0 - 7.5 kW motors must be connected to especially reliable/sturdy earth connections due to an earth leakage current above 3.5 mA.
- The pump requires no external motor protection. The motor incorporates thermal protection against slow overloading and blocking (IEC 34-11: TP 211).
- When the pump is switched on via the mains, the pump will start after approx. 5 secs.

Note: The number of starts and stops via the mains voltage must not exceed 4 times per hour.

The pump mains connection must be made as shown in the diagrams below.

Control options of CRE pumps

Communication with CRE pumps is possible by means of

- a central management system,
- remote control (Grundfos R100) or
- a control panel.

The purpose of controlling an E-pump is to monitor and control the pressure, temperature, flow and liquid level of the system.

Central management system

Communication with the CRE pump is possible even though the operator is not present near the CRE pump.

Communication is enabled by having connected the CRE pump to a central management system allowing the operator to monitor and change control modes and setpoint settings of the CRE pump.

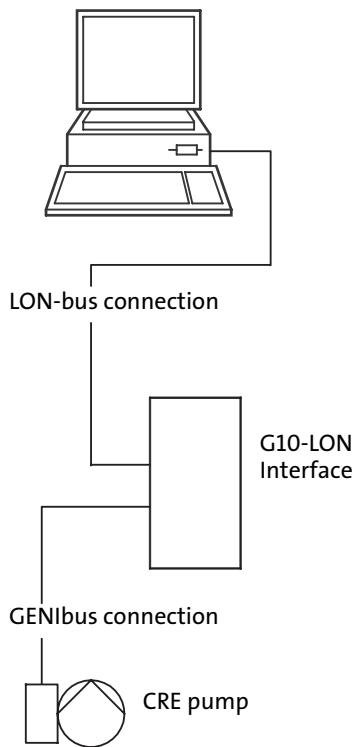

Fig. 4 Structure of a central management system

TM06592 1103

Remote control

The R100 remote control produced by Grundfos is available as an accessory.

The operator communicates with the CRE pump by pointing the IR-signal transmitter at the control panel of the E-pump terminal box.

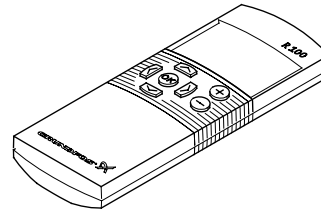

TM00 4498 2802

Fig. 5 R100 remote control

On the R100 display it is possible to monitor and change control modes and settings of the CRE pump.

Control panel

The control panel of the CRE pump terminal box makes it possible to change the setpoint settings manually.

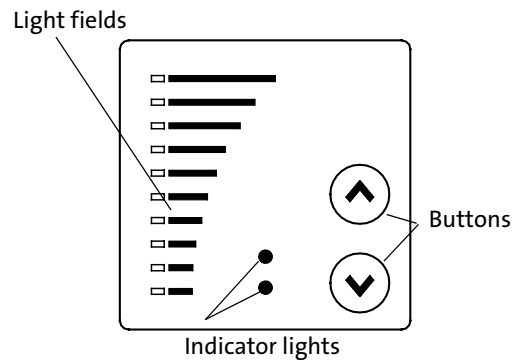

TM00 7600 0404

Fig. 6 Control panel on CRE pump

Overview of functions

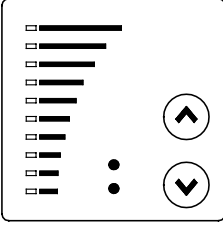
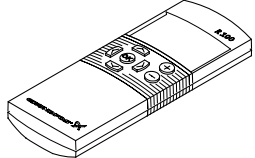
E-pumps/functions		Hydro Solo-E
 	Setting via control panel: Setpoint Start/stop Max. curve Min. curve	● ● ● ●
	Reading via control panel: Setpoint Operating indication Fault indication	● ● ●
Setting via R100: Setpoint Start/stop Max. curve Min. curve Controlled/uncontrolled PI-controller Signal relay Operating range Stop function	● ● ● ● ● ● ● ● ●	
Reading via R100: Setpoint Operating indication Pump status	● ● ●	

TM00 7600 0404

TM00 4498 2802

Additional protection

If the pump is connected to an electric installation where an earth leakage circuit breaker (ELCB) is used as an additional protection the earth leakage circuit breakers must be marked with the following symbols.

- Single-phase:



The earth leakage circuit breakers **must** trip out when earth fault currents with DC content (pulsating DC) occur.

- Three-phase:



The earth leakage circuit breakers **must** trip out when earth fault currents with DC content (pulsating DC) and smooth DC earth fault currents occur.

Wiring diagram, single-phase

1 x 200-240 V, +/-10%

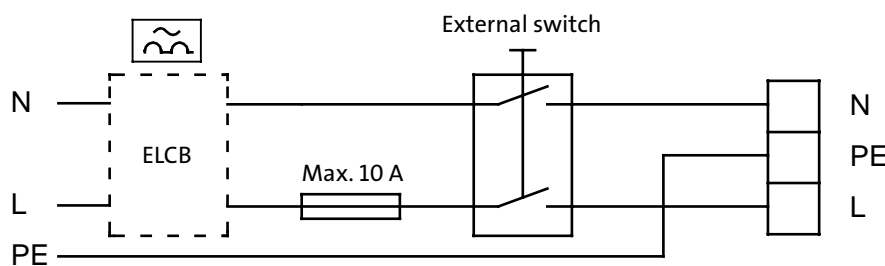

TM02 0792 0101

Wiring diagram, three-phase 1.5 - 7.5 kW

3 x 380-480 V, +/-10%

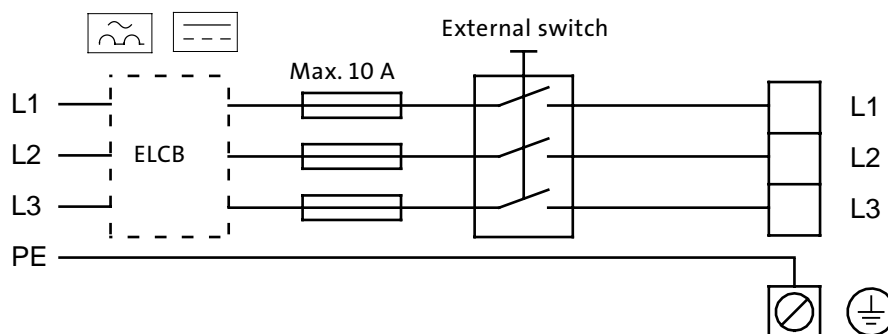

TM00 9270 4696

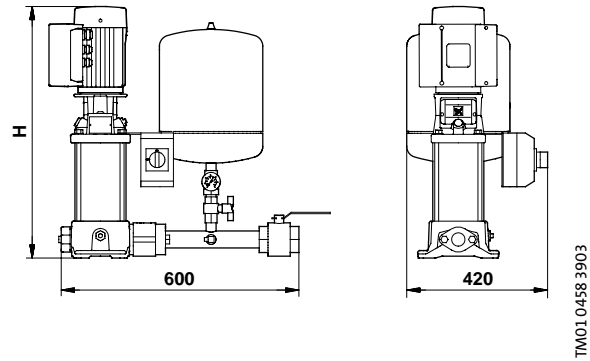
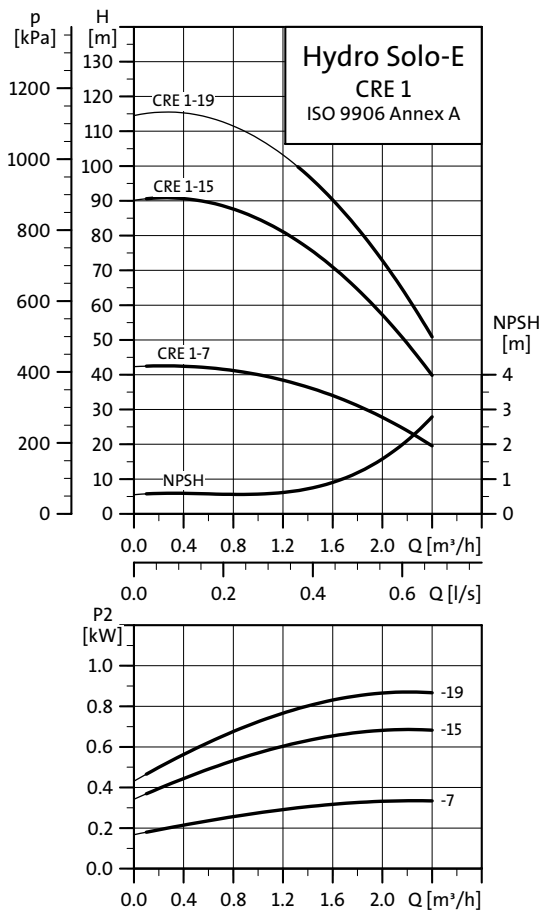

Electrical data, dimensions and weights

Pump type	Motor [kW]	Full load current 1/1 [A]	Supply voltage		Diaphragm tank [litres]	Connection		H [mm]	Weights [kg]		Packing [m³]
			1 x 220-240 V, PE	3 x 380-480 V, PE		inlet	outlet		Net	Gross	
CRE 1-7	0.37	3.0-2.5	●	-	8	Rp 1½	Rp 1½	537	39.0	42.0	0.6
CRE 1-15	0.75	5.10-4.70	●	-	8	Rp 1½	Rp 1½	707	44.7	47.7	0.6
CRE 1-19	1.1	7.40-6.80	●	-	8	Rp 1½	Rp 1½	779	47.2	50.2	0.6

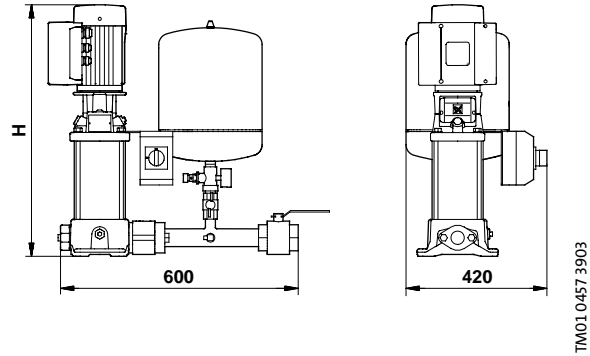
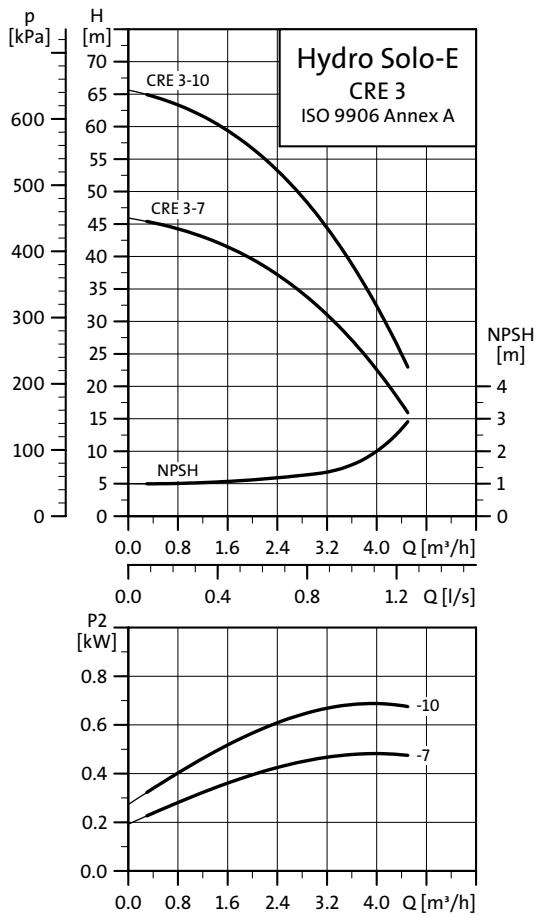

Electrical data, dimensions and weights

Pump type	Motor [kW]	Full load current 1/1 [A]	Supply voltage		Diaphragm tank [litres]	Connection		H [mm]	Weights [kg]		Packing [m³]
			1 x 220-240 V, PE	3 x 380-480 V, PE		inlet	outlet		Net	Gross	
CRE 3-7	0.55	4.30 - 3.60	●	-	8	Rp 1½	Rp 1½	519	39.6	42.9	0.6
CRE 3-10	0.75	5.10-4.70	●	-	8	Rp 1½	Rp 1½	617	42.9	45.9	0.6
CRE 3-10	1.1	2.60-2.30	-	●	8	Rp 1½	Rp 1½	617	42.9	45.9	0.6

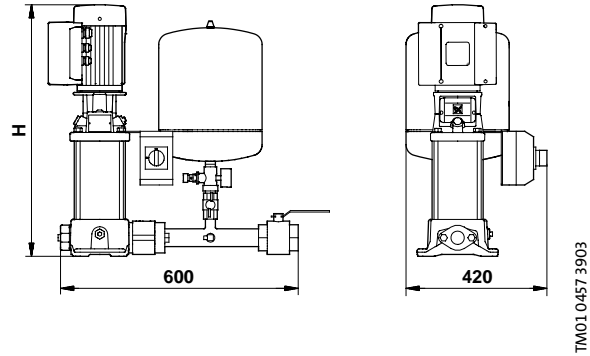
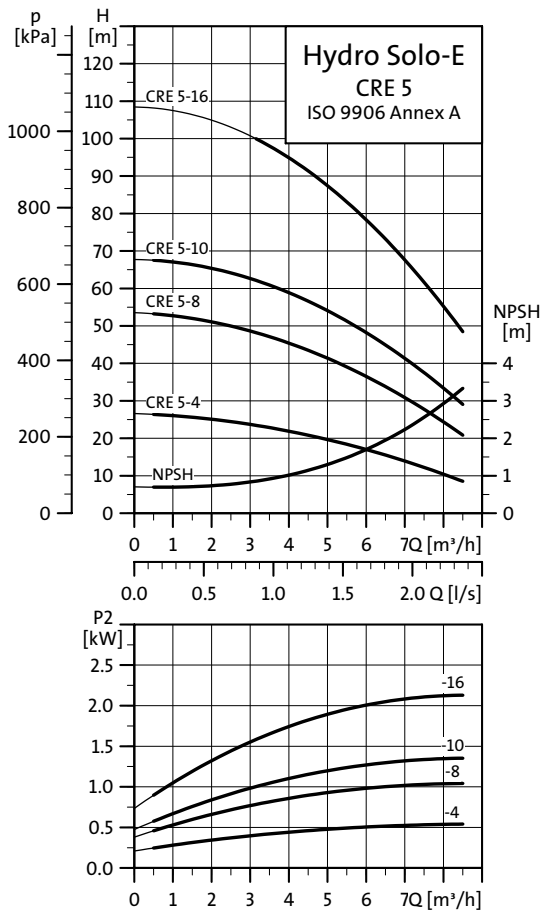

Electrical data, dimensions and weights

Pump type	Motor [kW]	Full load current 1/1 [A]	Supply voltage		Diaphragm tank [litres]	Connection		H [mm]	Weights [kg]		Packing [m³]
			1 x 220-240 V, PE	3 x 380-480 V, PE		inlet	outlet		Net	Gross	
CRE 5-4	0.55	4.3-3.6	●	-	18	Rp 1½	Rp 1½	501	40.8	43.8	0.6
CRE 5-8	1.1	7.40-6.80	●	-	18	Rp 1½	Rp 1½	653	47.0	50.0	0.6
CRE 5-8	1.1	2.60-2.30	-	●	18	Rp 1½	Rp 1½	653	47.0	50.0	0.6
CRE 5-10	1.5	3.30-2.70	-	●	18	Rp 1½	Rp 1½	773	56.6	59.6	0.6
CRE 5-16	2.2	4.60-3.80	-	●	18	Rp 1½	Rp 1½	773	61.8	64.8	0.6

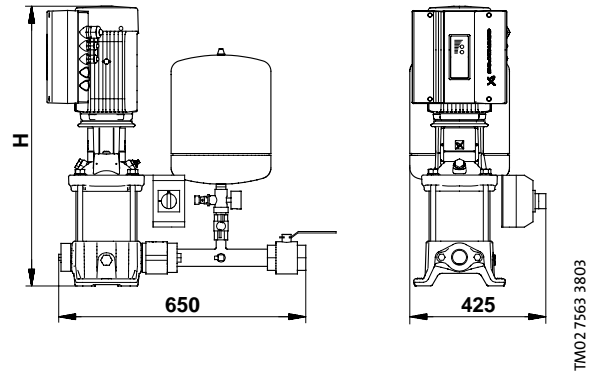
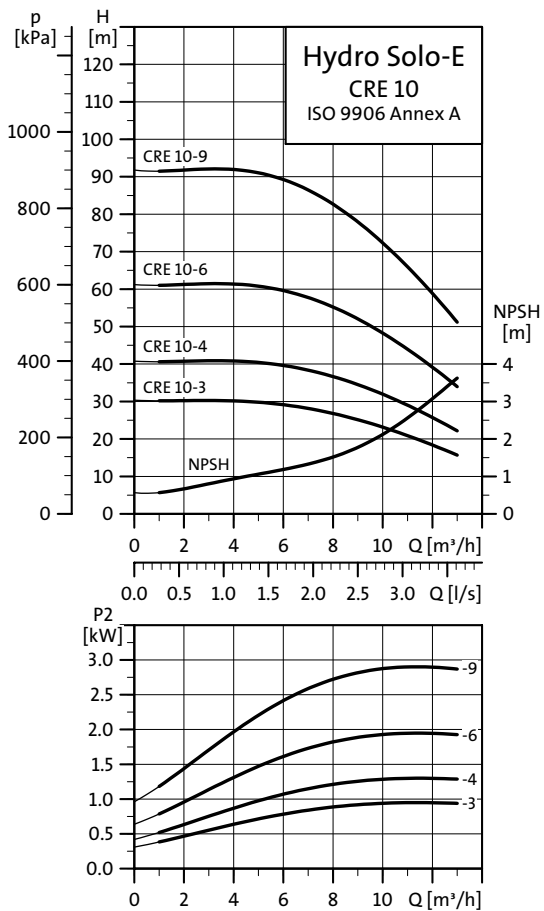

Electrical data, dimensions and weights

Pump type	Motor [kW]	Full load current 1/1 [A]	Supply voltage		Diaphragm tank [litres]	Connection		H [mm]	Weights [kg]		Packing [m³]
			1 x 220-240 V, PE	3 x 380-480 V, PE		inlet	outlet		Net	Gross	
CRE 10-3	1.1	7.40-6.80	●	-	33	Rp 1½	Rp 1½	608	62.0	65.0	0.6
CRE 10-4	1.5	3.30-2.70	-	●	33	Rp 1½	Rp 1½	704	71.0	74.0	0.6
CRE 10-6	2.2	4.60-3.80	-	●	33	Rp 1½	Rp 1½	804	80.0	83.0	0.6
CRE 10-9	3.0	6.40-5.20	-	●	33	Rp 1½	Rp 1½	913	87.0	90.0	0.6

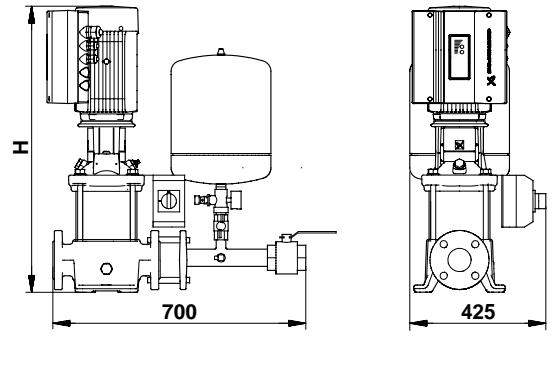
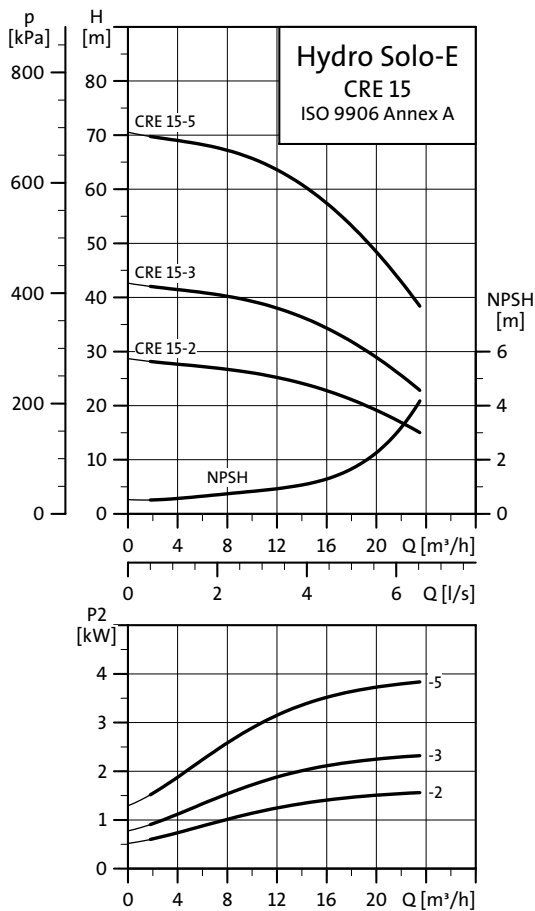

Electrical data, dimensions and weights

Pump type	Motor [kW]	Full load current 1/1 [A]	Supply voltage 3 x 380-480 V, PE	Diaphragm tank [litres]	Connection		H [mm]	Weights [kg]		Packing [m³]
					Suction side	Discharge side		Net	Gross	
CRE 15-2	2.2	4.60-3.80	●	33	DN 50	Rp 2	736	91.0	94.0	0.6
CRE 15-3	3.0	6.40-5.20	●	33	DN 50	Rp 2	800	96.0	99.0	0.6
CRE 15-5	4.0	8.10-6.60	●	33	DN 50	Rp 2	927	115.0	188.0	0.6

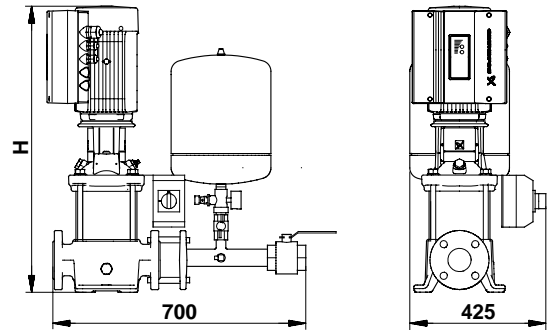
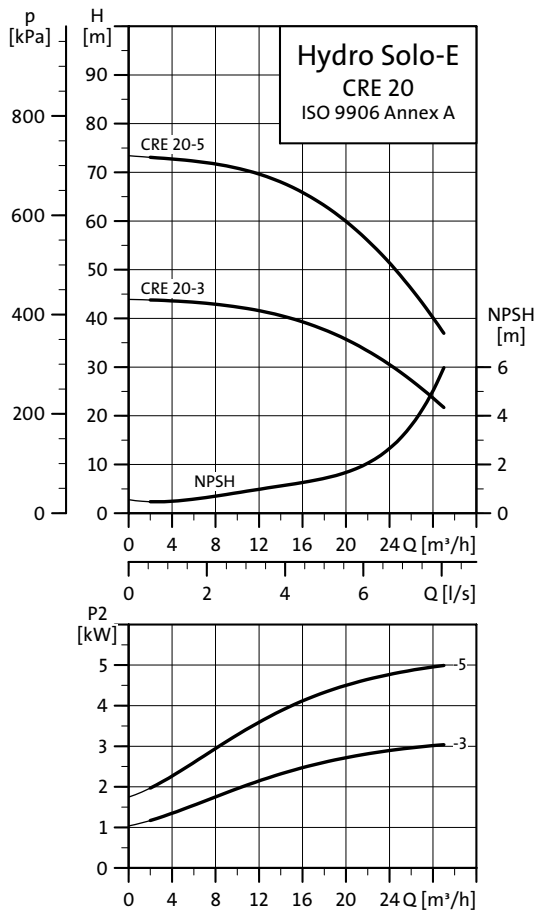

Electrical data, dimensions and weights

Pump type	Motor [kW]	Full load current 1/1 [A]	Supply voltage 3 x 380-480 V, PE	Diaphragm tank [litres]	Connection		H [mm]	Weights [kg]		Packing [m³]
					Suction side	Discharge side		Net	Gross	
CRE 20-3	4.0	8.10-6.60	●	33	DN 50	Rp 2	837	112.0	115.0	0.6
CRE 20-5	5.5	11.0-8.80	●	33	DN 50	Rp 2	978	136.0	133.0	0.6

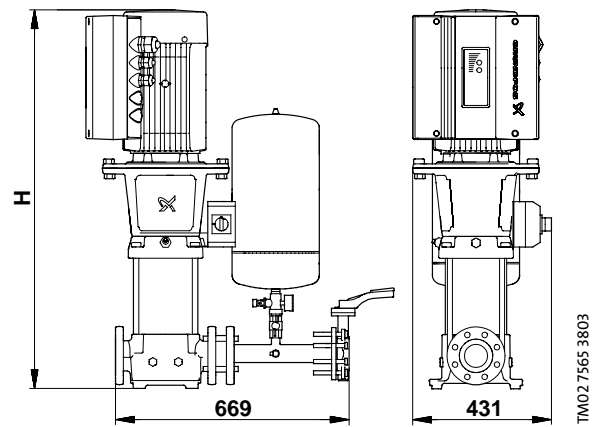
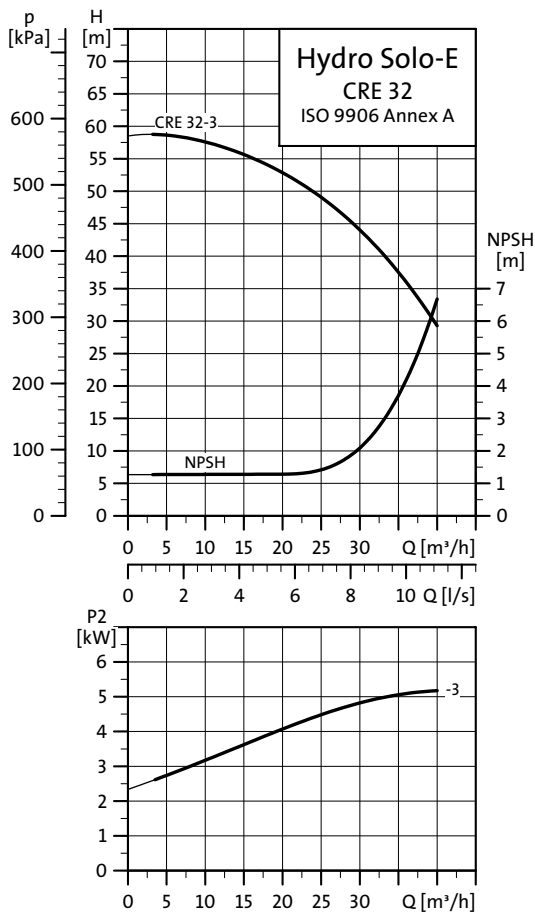

Electrical data, dimensions and weights

Pump type	Motor [kW]	Full load current I ₁ [A]	Supply voltage 3 x 380-480 V, PE	Diaphragm tank [litres]	Connection		H [mm]	Weights [kg]		Packing [m ³]
					Suction side	Discharge side		Net	Gross	
CRE 32-3	5.5	11.0-8.80	●	33	DN 65	DN 65	1036	138.0	143.0	0.6

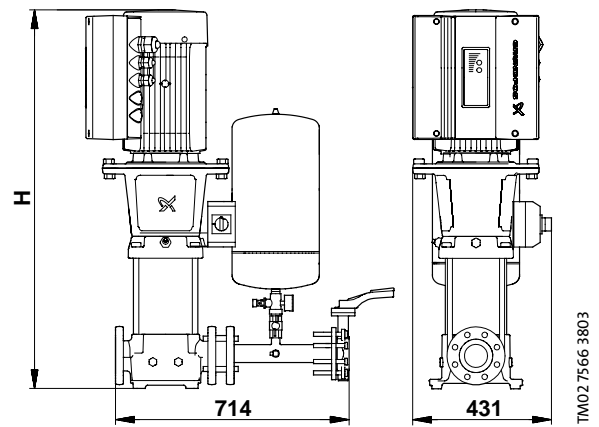
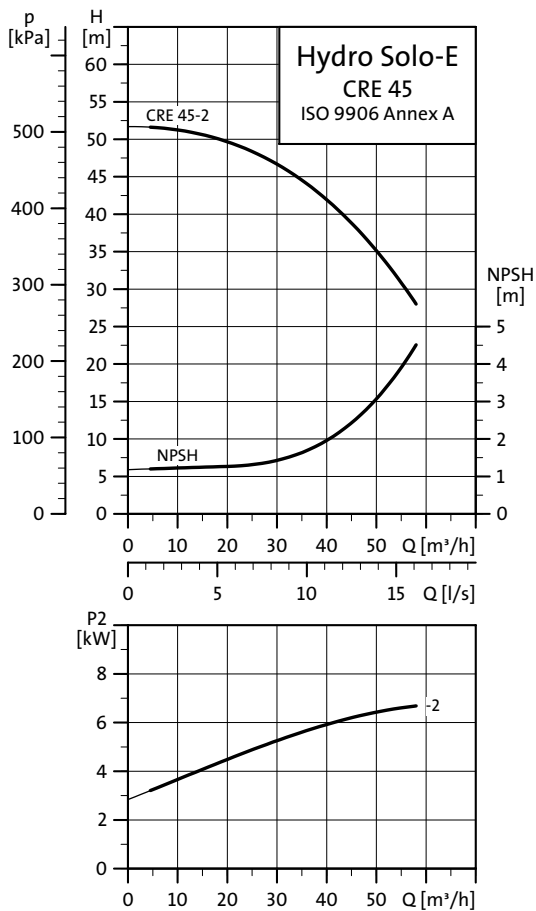

Electrical data, dimensions and weights

Pump type	Motor [kW]	Max. I_N [A]	Supply voltage 3 x 380-480 V, PE	Diaphragm tank [litres]	Connection		H [mm]	Weights [kg]		Packing [m³]
					Suction side	Discharge side		Net	Gross	
CRE 45-2	5.5	11.0-8.80	●	33	DN 80	DN 80	1029	146.0	149.0	0.6

R100

R100 is used for wireless communication. The communication takes place by means of infrared light.

Product	Product number
R100	625333

Dry-running protection

Type	Pressure [bar]	Product number
	0.11 - 2	96421253
Hydro Solo-E	0.22 - 4	96421254
	0.5 - 8	96421255

To protect the booster set against dry running, dry-running protection is **obligatory**. The dry-running protection unit is to be mounted on the site.

Automatic reset after water shortage

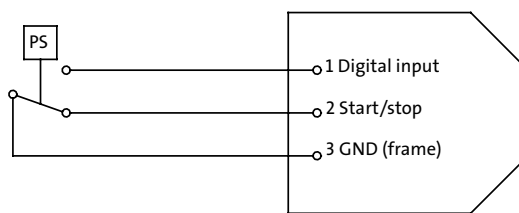
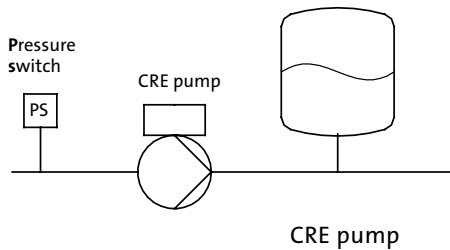

TM02 2560 4003

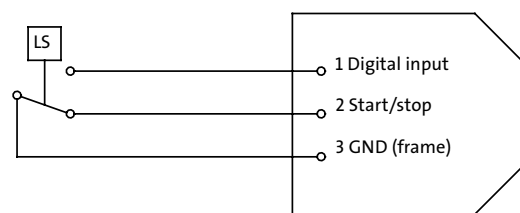
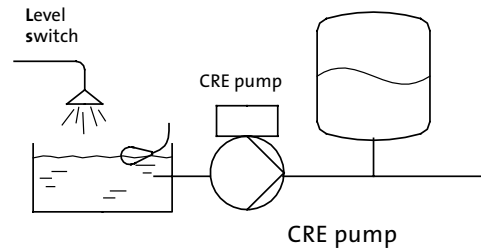

TM02 2589 4003

Manual reset after water shortage

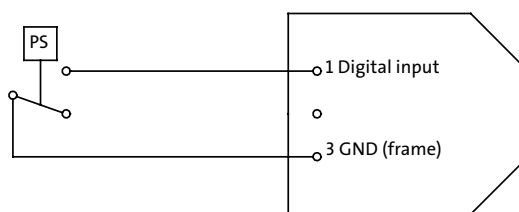
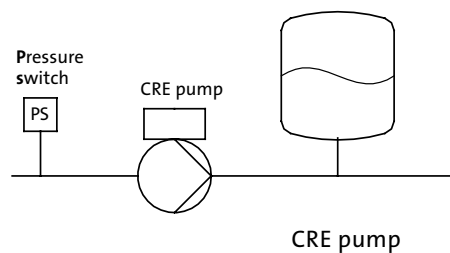

TM02 2561 4003

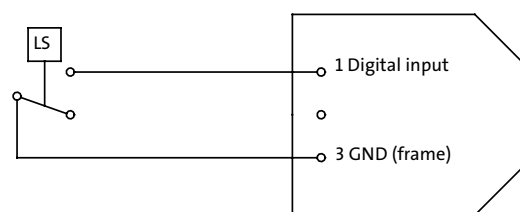
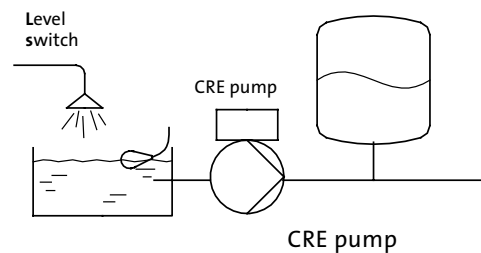

TM02 2590 4003

Further product documentation

In addition to the printed data booklet, Grundfos offers the following sources of product documentation.

- WinCAPS
- WebCAPS.

WinCAPS

WinCAPS is a **Windows-based Computer-Aided Product Selection** program containing information on more than 90,000 Grundfos products.

Available on CD-ROM in more than 15 languages, WinCAPS offers

- detailed technical information
- selection of the optimum pump solution
- dimensional drawings of each pump
- detailed service documentation
- installation and operating instructions
- wiring diagrams of each pump.



Fig. 7 WinCAPS CD-ROM

cd-wincaps

Click on **Catalogue** and select a product from the extensive product catalogue.

Click on **Sizing** and select the most suitable pump for your application.



Fig. 8 WinCAPS

WinCAPS

Further product documentation

WebCAPS

WebCAPS is a **Web**-based Computer Aided-Product Selection program and a web-version of WinCAPS.

Available on Grundfos' homepage, www.grundfos.com, WebCAPS offers

- detailed technical information
- dimensional drawings of each pump
- wiring diagrams of each pump.

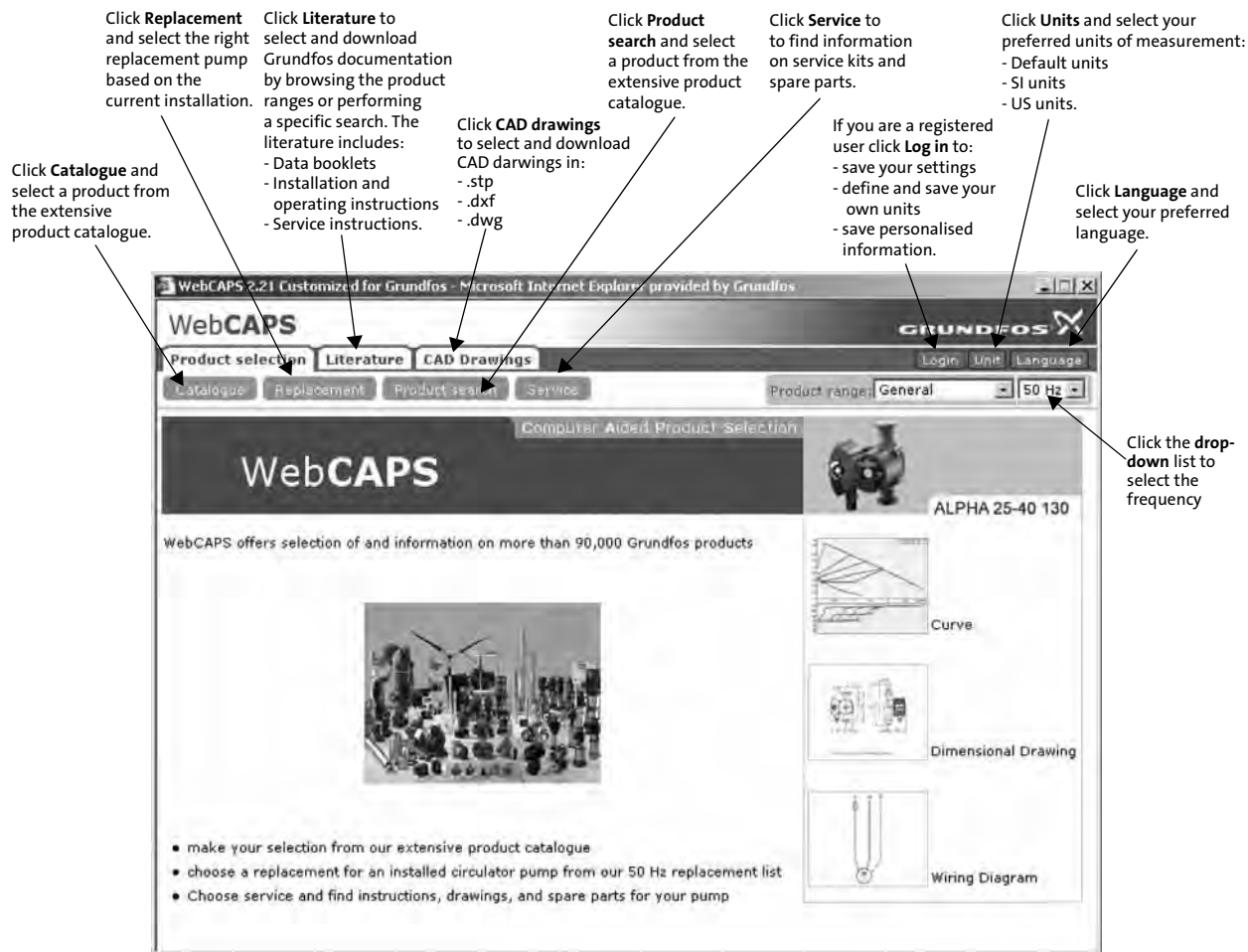

Fig. 9 WebCAPS

WebCAPS



V7140010 0305	GB
Repl. V7140010 0604	

Subject to alterations.